

LVS Series



LVS series, an automatic assembly power inductor, is shielded with magnetic resin and suitable for the portable DC-DC converter application.

Features

- RoHS compliant
- Highly accurate dimensions can be mounted automatically.
- Terminals are highly resistant to pull forces.
- Highly reliable in environments of sudden temperature change and humidity.
- Superior EMI electrical with ultra low radiation comparing to conventional shielded power inductors.

Applications

- LCD TV, Monitor, Ap Router, STB, Smart Phone, Touch Panel, DSC, Game Console and other electronic devices.

Product Identification

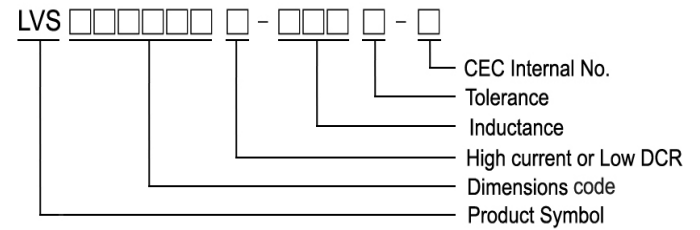
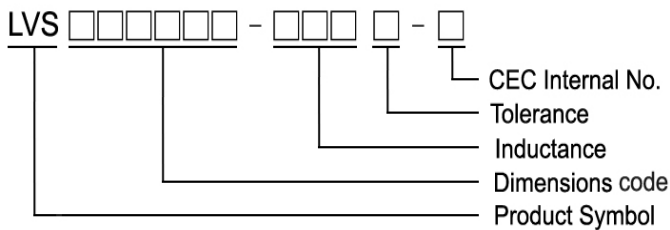

Shapes and Dimensions

Figure 1

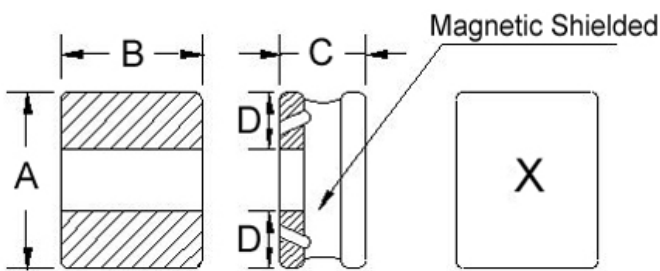

Recommended Pattern

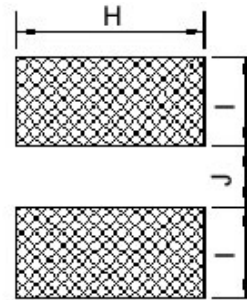

Dimensions in mm

TYPE	FIG	A	B	C Max	D	H	I	J
LVS201610	1	2.0±0.2	1.6±0.2	1.02	0.6	1.8	0.80	0.8
LVS252010	1	2.5±0.2	2.0±0.2	1.02	0.8	2.0	0.85	0.8
LVS252010D	1	2.5±0.2	2.0±0.2	1.02	0.8	2.0	0.85	0.8
LVS252012	1	2.5±0.2	2.0±0.2	1.20	0.8	2.0	0.85	0.8
LVS252012L	1	2.5±0.2	2.0±0.2	1.20	0.8	2.0	0.85	0.8
LVS252012D	1	2.5±0.2	2.0±0.2	1.20	0.8	2.0	0.85	0.8

Shapes and Dimensions

Figure 2

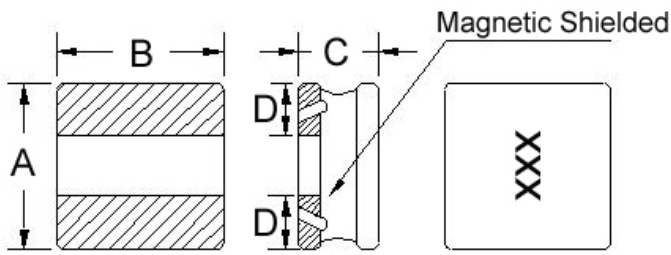

Recommended Pattern

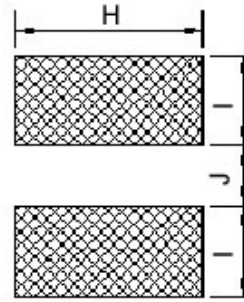

Dimensions in mm

TYPE	FIG	A	B	C	D	H	I	J
LVS303010	2	3.0±0.2	3.0±0.2	1.02Max.	1.0	3.0	1.0	1.0
LVS303010H	2	3.0±0.2	3.0±0.2	1.02Max.	1.0	3.0	1.0	1.0
LVS303012	2	3.0±0.2	3.0±0.2	1.20Max.	1.0	3.0	1.0	1.0
LVS303012H	2	3.0±0.2	3.0±0.2	1.20Max.	1.0	3.0	1.0	1.0
LVS303015	2	3.0±0.2	3.0±0.2	1.50Max.	1.0	3.0	1.0	1.0
LVS303015H	2	3.0±0.2	3.0±0.2	1.50Max.	1.0	3.0	1.0	1.0
LVS404010	2	4.0±0.2	4.0±0.2	1.20±0.2	1.3	4.2	1.5	1.2
LVS404012	2	4.0±0.2	4.0±0.2	1.20±0.1	1.5	4.2	1.5	1.2

Shapes and Dimensions

Figure 3

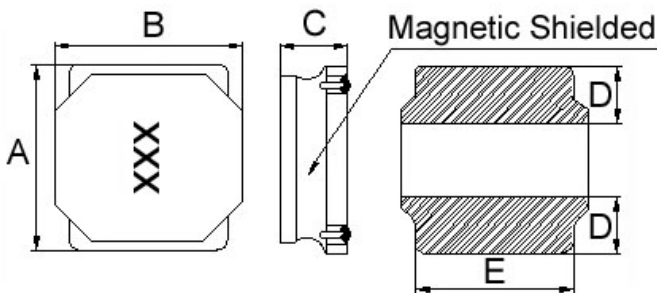
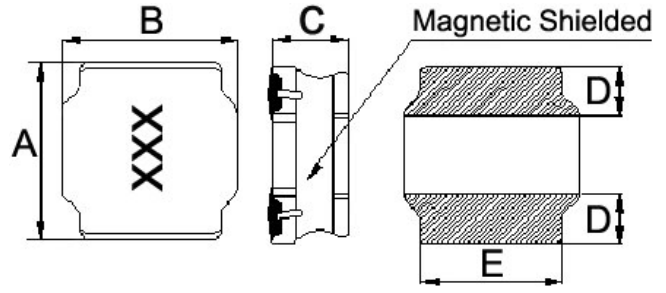

Figure 4



Dimensions in mm

TYPE	FIG	A	B	C	D	E	H	I	J
LVS404018	3	4.0±0.2	4.0±0.2	1.8 ^{+0.2} _{-0.30}	1.3±0.3	3.6	3.7	1.2	1.6
LVS505020	4	5.0±0.2	5.0±0.2	2.0 ^{+0.2} _{-0.30}	1.8±0.3	4.0	4.0	1.5	2.1
LVS505040	4	5.0±0.2	5.0±0.2	4.0 ^{+0.2} _{-0.30}	1.6±0.3	4.0	4.0	1.5	2.1
LVS606020	4	6.0±0.2	6.0±0.2	2.0 ^{+0.2} _{-0.30}	1.7±0.3	5.0	5.7	1.6	2.9
LVS606028	3	6.0±0.2	6.0±0.2	2.8 ^{+0.2} _{-0.30}	1.9±0.3	4.8	5.7	1.6	2.9
LVS606045	4	6.0±0.2	6.0±0.2	4.5 ^{+0.2} _{-0.30}	1.8±0.3	5.0	5.7	1.6	2.9
LVS606045L	4	6.0±0.2	6.0±0.2	4.5 ^{+0.2} _{-0.30}	1.8±0.3	5.0	5.7	1.6	2.9
LVS808040	4	8.0±0.2	8.0±0.2	4.0 ^{+0.2} _{-0.30}	2.3±0.3	6.3	7.5	2.1	3.8
LVS808040L	4	8.0±0.2	8.0±0.2	4.0 ^{+0.2} _{-0.30}	2.3±0.3	6.3	7.5	2.1	3.8

Recommended Pattern

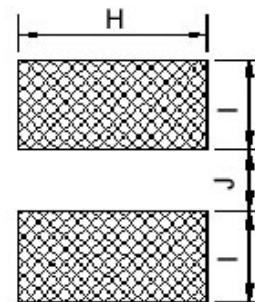

Electrical Characteristics

Part Number	Inductance (uH)	Test Frequency (MHz)	Tolerance (±%)	RDC (Ω) ±30%	Isat (mA)Typ	Irms (mA)Typ	Marking
LVS201610-1R0□-N	1.0	1	20, 30	0.17	1400	1600	A
LVS201610-1R5□-N	1.5	1	20, 30	0.26	1100	1400	B
LVS201610-2R2□-N	2.2	1	20, 30	0.32	1000	1200	C
LVS201610-3R3□-N	3.3	1	20, 30	0.51	820	900	D
LVS201610-4R7□-N	4.7	1	20, 30	0.67	680	800	E
LVS201610-5R6□-N	5.6	1	20, 30	0.72	650	800	F
LVS201610-6R8□-N	6.8	1	20, 30	0.97	560	700	G
LVS201610-100□-N	10	1	20, 30	1.45	470	580	H
LVS201610-220□-N	22	1	20, 30	2.90	310	400	I

- When ordering, please specify tolerance and packaging codes.
- Tolerance : T = ±30% , M = ±20%
- L : Agilent/HP4287A+ Agilent/HP16197A, 1MHz 200mV
- RDC : Digital Milliohm Meter Chroma 16502, or equivalent
- Isat & Irms : Agilent/HP4284A, 1MHz 200mV
- Isat for Inductance drop 30% from its value without current.
- Irms for a 40°C rise above 25°C ambient.
- Operating temperature range from -25°C to 105°C. (Including self - temperature rise)

Test Instruments : HP4284A Material/Impedance Analyzer

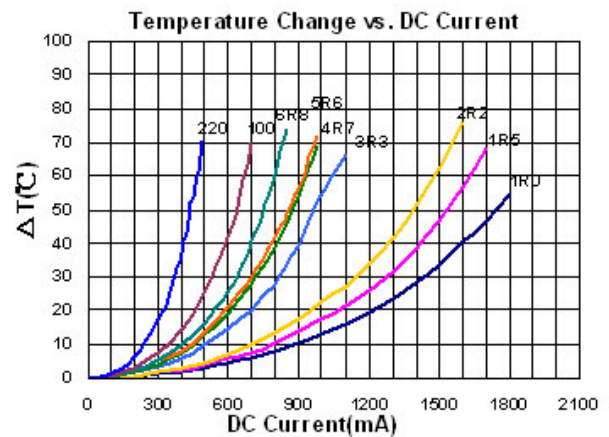
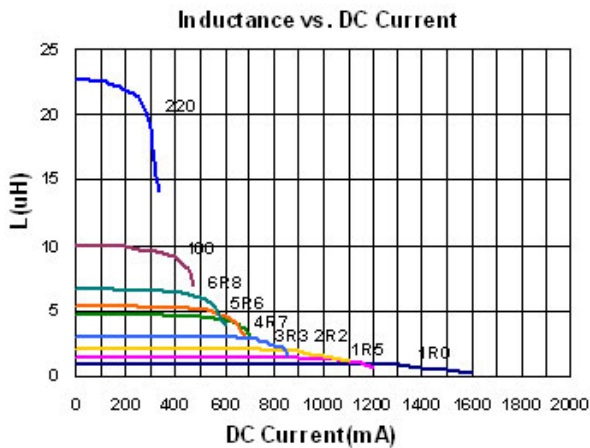

Electrical Characteristics

Part Number	Inductance (uH)	Test Frequency (MHz)	Tolerance (±%)	RDC (Ω) ±30%	Isat (mA)Typ	Irms (mA)Typ	Marking
LVS252010-1R0□-N	1.0	1	20, 30	0.093	2200	2200	A
LVS252010-1R5□-N	1.5	1	20, 30	0.148	1900	1800	B
LVS252010-2R2□-N	2.2	1	20, 30	0.178	1620	1680	C
LVS252010-3R3□-N	3.3	1	20, 30	0.286	1220	1340	D
LVS252010-4R7□-N	4.7	1	20, 30	0.421	1040	1020	E
LVS252010-5R6□-N	5.6	1	20, 30	0.481	920	840	F
LVS252010-6R8□-N	6.8	1	20, 30	0.598	900	880	G
LVS252010-100□-N	10	1	20, 30	0.797	740	820	H
LVS252010-150□-N	15	1	20, 30	1.450	520	400	L
LVS252010-220□-N	22	1	20, 30	1.839	500	520	I

- When ordering, please specify tolerance and packaging codes.
- Tolerance : T = ±30% , M = ±20%
- Packaging: Clear tape and reel {standard}.
- L : Agilent/HP4287A+ Agilent/HP16197A, 1MHz 200mV
- RDC : Digital Milliohm Meter Chroma 16502,or equivalent
- Isat & Irms : Agilent/HP4284A, 1MHz 200mV
- Isat for Inductance drop 30% from its value without current.
- Irms for a 40°C rise above 25°C ambient.
- Operating temperature range from -25°C to 105°C. (Including self - temperature rise)

Test Instruments : HP4284A Material/Impedance Analyzer

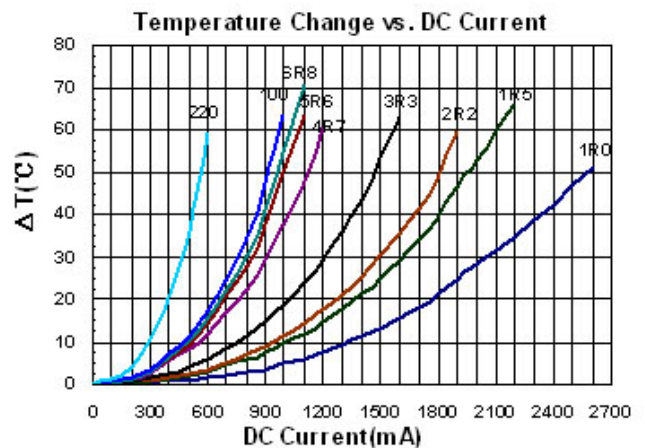
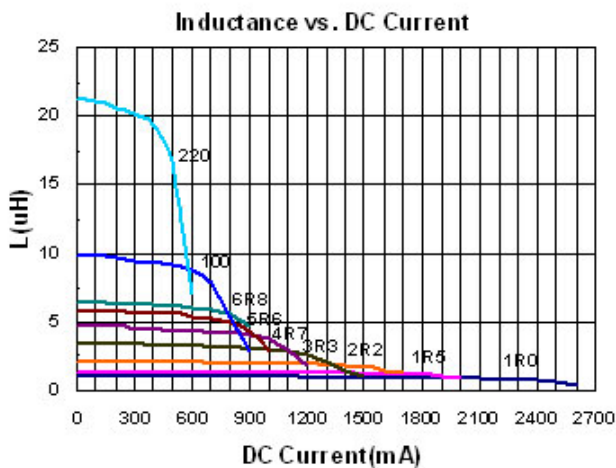

Electrical Characteristics

Part Number	Inductance (uH)	Test Frequency (MHz)	Tolerance (±%)	RDC (Ω) ±30%	Isat (mA)Typ	Irms (mA)Typ	Marking
LVS252010D-1R0□-N	1.0	1	20, 30	0.085	1500	2300	A
LVS252010D-1R5□-N	1.5	1	20, 30	0.125	1100	1800	B
LVS252010D-2R2□-N	2.2	1	20, 30	0.150	1000	1700	C
LVS252010D-3R3□-N	3.3	1	20, 30	0.220	860	1400	D
LVS252010D-4R7□-N	4.7	1	20, 30	0.300	720	1000	E
LVS252010D-5R6□-N	5.6	1	20, 30	0.360	650	950	F
LVS252010D-6R8□-N	6.8	1	20, 30	0.440	600	900	G
LVS252010D-100□-N	10	1	20, 30	0.605	520	800	H
LVS252010D-220□-N	22	1	20, 30	1.500	340	500	I

- When ordering, please specify tolerance and packaging codes.
- Tolerance : T = ±30% , M = ±20%
- Packaging: Clear tape and reel {standard}.
- L : Agilent/HP4287A+ Agilent/HP16197A, 1MHz 200mV
- RDC : Digital Milliohm Meter Chroma 16502,or equivalent
- Isat & Irms : Agilent/HP4284A, 1MHz 200mV
- Isat for Inductance drop 30% from its value without current.
- Irms for a 40°C rise above 25°C ambient.
- Operating temperature range from -25°C to 105°C . (Including self - temperature rise)

Test Instruments : HP4284A Material/Impedance Analyzer

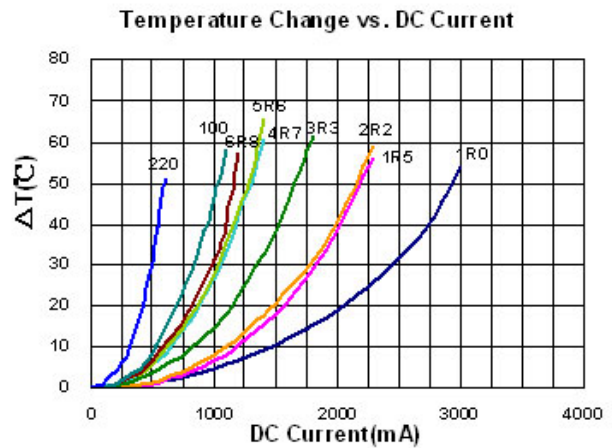
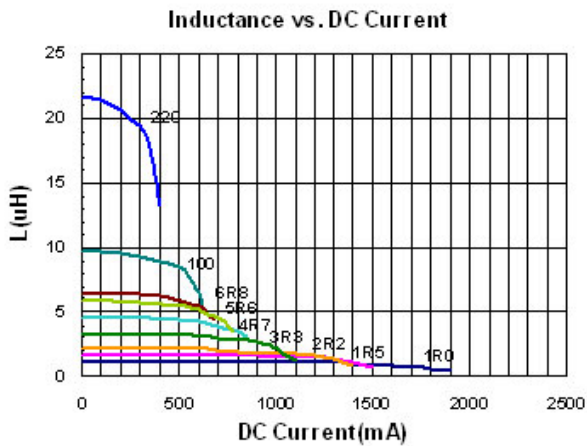

Electrical Characteristics

Part Number	Inductance (uH)	Test Frequency (MHz)	Tolerance (±%)	RDC (Ω) ±30%	Isat (mA)Typ	Irms (mA)Typ	Marking
LVS252012-1R0□-N	1.0	1	20, 30	0.105	2800	2200	A
LVS252012-1R5□-N	1.5	1	20, 30	0.153	2200	1860	B
LVS252012-2R2□-N	2.2	1	20, 30	0.219	1800	1700	C
LVS252012-3R3□-N	3.3	1	20, 30	0.349	1300	1200	D
LVS252012-4R7□-N	4.7	1	20, 30	0.507	1100	1040	E
LVS252012-5R6□-N	5.6	1	20, 30	0.525	1100	1000	F
LVS252012-6R8□-N	6.8	1	20, 30	0.760	940	940	G
LVS252012-100□-N	10	1	20, 30	0.915	820	840	H
LVS252012-220□-N	22	1	20, 30	2.110	550	540	I

- When ordering, please specify tolerance and packaging codes.
- Tolerance : T = ±30% , M = ±20%
- L : Agilent/HP4287A+ Agilent/HP16197A, 1MHz 200mV
- RDC : Digital Milliohm Meter Chroma 16502,or equivalent
- Isat & Irms : Agilent/HP4284A, 1MHz 200mV
- Isat for Inductance drop 30% from its value without current.
- Irms for a 40°C rise above 25°C ambient.
- Operating temperature range from -25°C to 105°C . (Including self - temperature rise)

Test Instruments : HP4284A Material/Impedance Analyzer

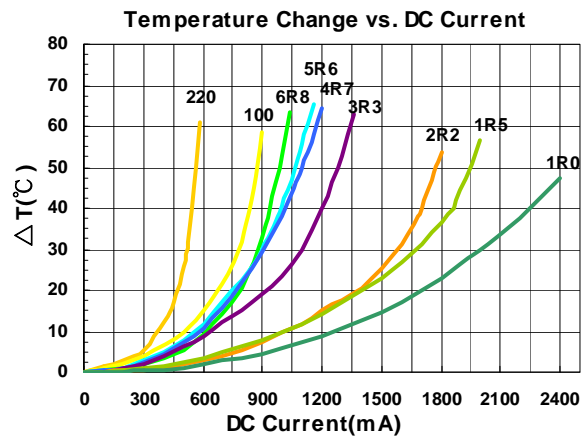
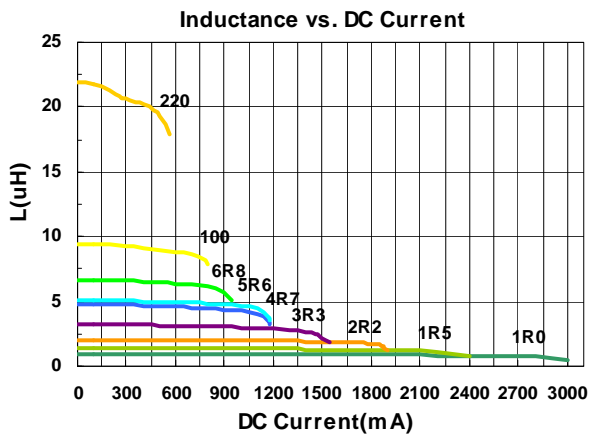

Electrical Characteristics

Part Number	Inductance (uH)	Test Frequency (MHz)	Tolerance (±%)	RDC (Ω) ±30%	Isat (mA)Typ	Irms (mA)Typ	Marking
LVS252012L-1R0□-N	1.0	1	20, 30	0.075	2300	2700	A
LVS252012L-1R5□-N	1.5	1	20, 30	0.114	1900	2500	B
LVS252012L-2R2□-N	2.2	1	20, 30	0.138	1600	2100	C
LVS252012L-3R3□-N	3.3	1	20, 30	0.215	1300	1700	D
LVS252012L-4R7□-N	4.7	1	20, 30	0.312	1000	1400	E
LVS252012L-5R6□-N	5.6	1	20, 30	0.393	920	990	F
LVS252012L-6R8□-N	6.8	1	20, 30	0.466	890	960	G
LVS252012L-100□-N	10	1	20, 30	0.702	730	820	H
LVS252012L-220□-N	22	1	20, 30	1.470	490	540	I

- When ordering, please specify tolerance and packaging codes.
- Tolerance : T = ±30% , M = ±20%
- L : Agilent/HP4287A+ Agilent/HP16197A, 1MHz 200mV
- RDC : Digital Milliohm Meter Chroma 16502,or equivalent
- Isat & Irms : Agilent/HP4284A, 1MHz 200mV
- Isat for Inductance drop 30% from its value without current.
- Irms for a 40°C rise above 25°C ambient.
- Operating temperature range from -25°C to 105°C . (Including self - temperature rise)

Test Instruments : HP4284A Material/Impedance Analyzer

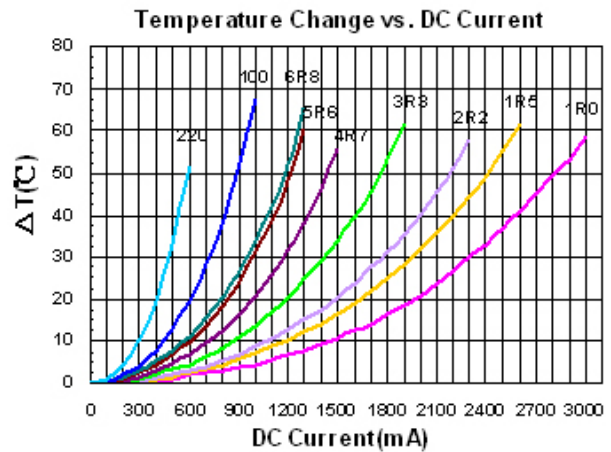
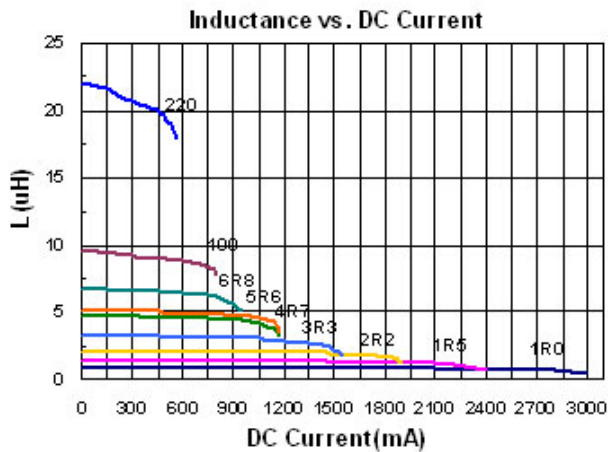

Electrical Characteristics

Part Number	Inductance (uH)	Test Frequency (MHz)	Tolerance (±%)	RDC (Ω) ±30%	Isat (mA)Typ	Irms (mA)Typ	Marking
LVS252012D-1R0□-N	1.0	1	20, 30	0.068	1700	2500	A
LVS252012D-1R5□-N	1.5	1	20, 30	0.096	1400	2200	B
LVS252012D-2R2□-N	2.2	1	20, 30	0.104	1300	2100	C
LVS252012D-3R3□-N	3.3	1	20, 30	0.173	900	1500	D
LVS252012D-4R7□-N	4.7	1	20, 30	0.260	850	1300	E
LVS252012D-5R6□-N	5.6	1	20, 30	0.292	780	1200	F
LVS252012D-6R8□-N	6.8	1	20, 30	0.400	670	1000	G
LVS252012D-100□-N	10	1	20, 30	0.500	580	850	H
LVS252012D-220□-N	22	1	20, 30	1.150	370	600	I
LVS252012D-330□-N	33	1	20, 30	1.500	350	520	J

- When ordering, please specify tolerance and packaging codes.
- Tolerance : T = ±30% , M = ±20%
- L : Agilent/HP4287A+ Agilent/HP16197A, 1MHz 200mV
- RDC : Digital Milliohm Meter Chroma 16502, or equivalent
- Isat & I rms : Agilent/HP4284A, 1MHz 200mV
- Isat for Inductance drop 30% from its value without current.
- I rms for a 40°C rise above 25°C ambient.
- Operating temperature range from -25°C to 105°C. (Including self - temperature rise)

Test Instruments : HP4284A Material/Impedance Analyzer

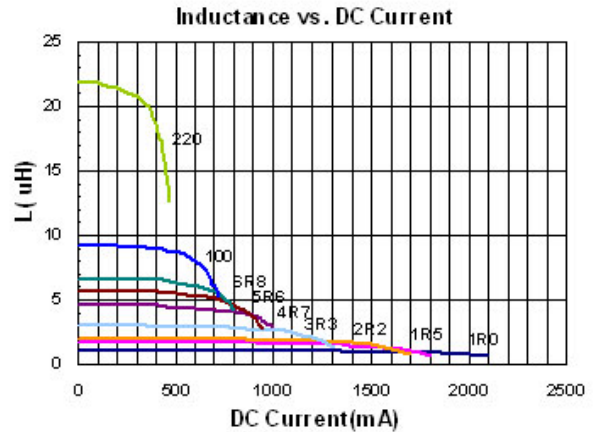
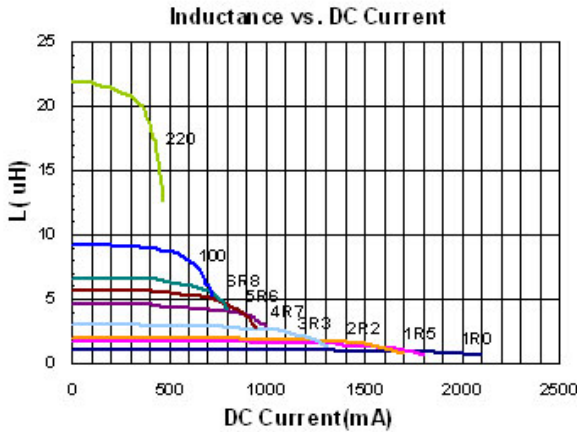

Electrical Characteristics

Part Number	Inductance (uH)	Test Frequency (MHz)	Tolerance (±%)	RDC (Ω) ±30%	Isat (mA)Typ	Irms (mA)Typ	Marking
LVS303010-1R0□-N	1.0	1	20, 30	0.063	1300	2400	1R0
LVS303010-1R5□-N	1.5	1	20, 30	0.077	1100	2200	1R5
LVS303010-2R2□-N	2.2	1	20, 30	0.087	960	2000	2R2
LVS303010-3R3□-N	3.3	1	20, 30	0.127	780	1600	3R3
LVS303010-4R7□-N	4.7	1	20, 30	0.186	650	1300	4R7
LVS303010-6R8□-N	6.8	1	20, 30	0.253	560	1000	6R8
LVS303010-100□-N	10	1	20, 30	0.353	430	880	100
LVS303010-220□-N	22	1	20, 30	0.693	310	580	220

- When ordering, please specify tolerance and packaging codes.
- Tolerance : T = ±30% , M = ±20%
- L : Agilent/HP4287A+ Agilent/HP16197A, 1MHz 200mV
- RDC : Digital Milliohm Meter Chroma 16502, or equivalent
- Isat & I rms : Agilent/HP4284A, 1MHz 200mV
- Isat for Inductance drop 30% from its value without current.
- I rms for a 40°C rise above 25°C ambient.
- Operating temperature range from -25°C to 105°C. (Including self - temperature rise)

Test Instruments : HP4284A Material/Impedance Analyzer

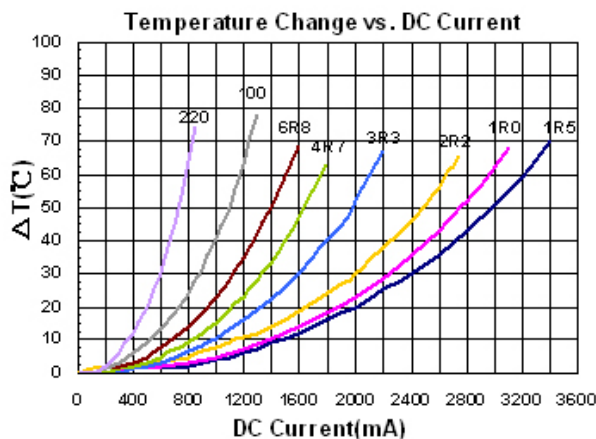
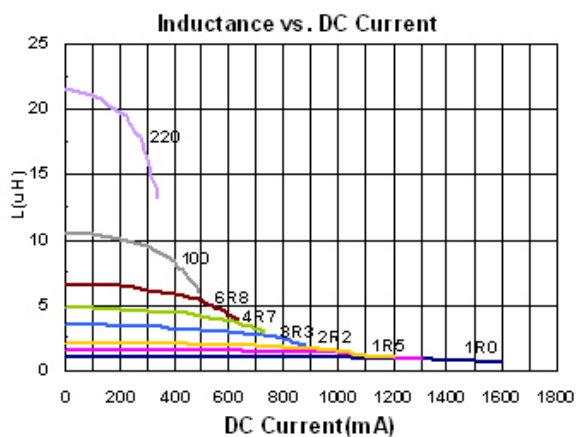

Electrical Characteristics

Part Number	Inductance (uH)	Test Frequency (MHz)	Tolerance (±%)	RDC (Ω) ±30%	Isat (mA)Typ	Irms (mA)Typ	Marking
LVS303010H-1R0□-N	1.0	1	20, 30	0.060	1800	2200	1R0
LVS303010H-1R5□-N	1.5	1	20, 30	0.075	1600	2100	1R5
LVS303010H-2R2□-N	2.2	1	20, 30	0.095	1400	1900	2R2
LVS303010H-3R3□-N	3.3	1	20, 30	0.140	1000	1300	3R3
LVS303010H-4R7□-N	4.7	1	20, 30	0.190	850	1200	4R7
LVS303010H-6R8□-N	6.8	1	20, 30	0.275	720	1000	6R8
LVS303010H-100□-N	10	1	20, 30	0.440	610	860	100
LVS303010H-220□-N	22	1	20, 30	0.800	420	620	220

- When ordering, please specify tolerance and packaging codes.
- Tolerance : T = ±30% , M = ±20%
- L : Agilent/HP4287A+ Agilent/HP16197A, 1MHz 200mV
- RDC : Digital Milliohm Meter Chroma 16502, or equivalent
- Isat & Irms : Agilent/HP4284A, 1MHz 200mV
- Isat for Inductance drop 30% from its value without current.
- Irms for a 40°C rise above 25°C ambient.
- Operating temperature range from -25°C to 105°C. (Including self - temperature rise)

Test Instruments : HP4284A Material/Impedance Analyzer

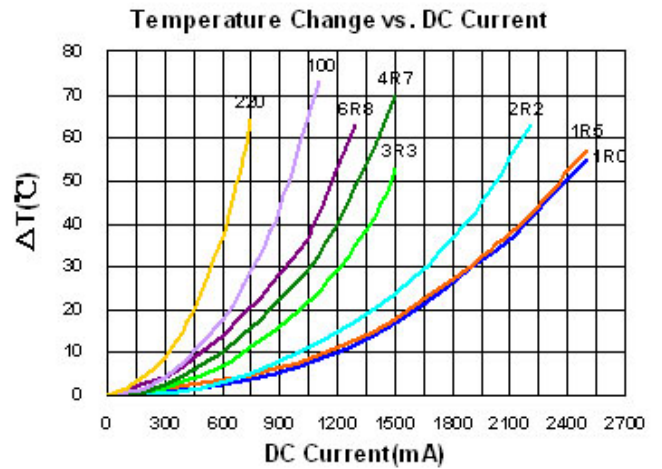
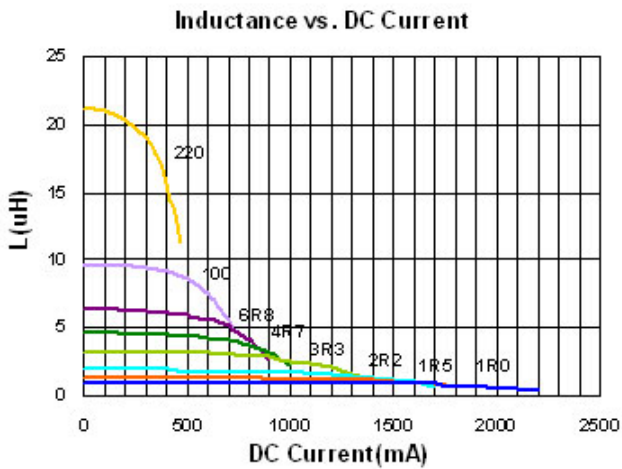

Electrical Characteristics

Part Number	Inductance (uH)	Test Frequency (MHz)	Tolerance (±%)	RDC (Ω) ±30%	Isat (mA)Typ	Irms (mA)Typ	Marking
LVS303012-1R0□-N	1.0	1	20, 30	0.048	1600	2500	1R0
LVS303012-1R5□-N	1.5	1	20, 30	0.063	1200	2300	1R5
LVS303012-2R2□-N	2.2	1	20, 30	0.076	1100	2000	2R2
LVS303012-3R3□-N	3.3	1	20, 30	0.102	900	1600	3R3
LVS303012-4R7□-N	4.7	1	20, 30	0.136	750	1500	4R7
LVS303012-6R8□-N	6.8	1	20, 30	0.182	630	1300	6R8
LVS303012-100□-N	10	1	20, 30	0.275	520	1000	100
LVS303012-220□-N	22	1	20, 30	0.594	350	650	220

- When ordering, please specify tolerance and packaging codes.
- Tolerance : T = ±30% , M = ±20%
- L : Agilent/HP4287A+ Agilent/HP16197A, 1MHz 200mV
- RDC : Digital Milliohm Meter Chroma 16502, or equivalent
- Isat & I rms : Agilent/HP4284A, 1MHz 200mV
- Isat for Inductance drop 30% from its value without current.
- I rms for a 40°C rise above 25°C ambient.
- Operating temperature range from -25°C to 105°C. (Including self - temperature rise)

Test Instruments : HP4284A Material/Impedance Analyzer

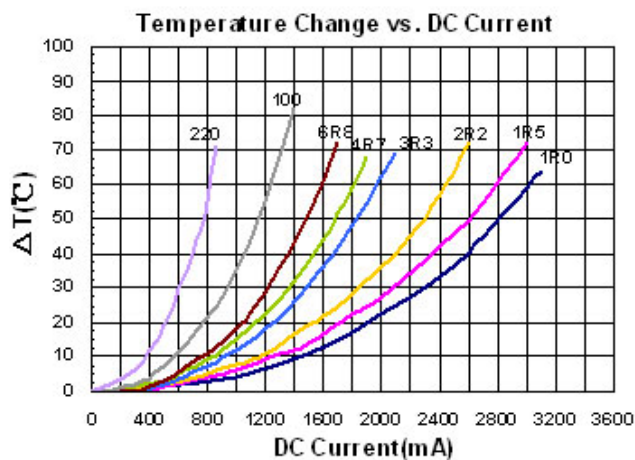
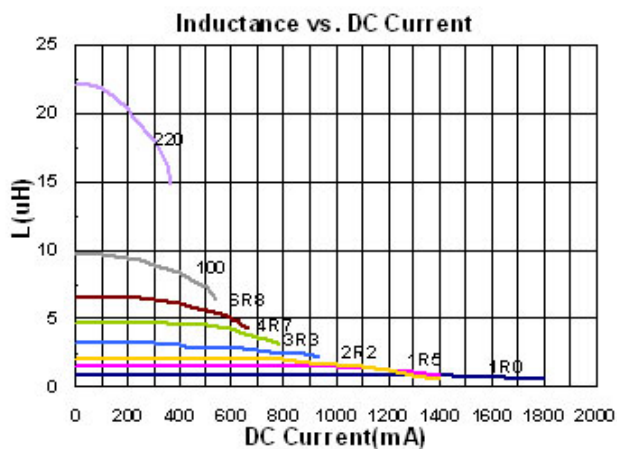

Electrical Characteristics

Part Number	Inductance (uH)	Test Frequency (MHz)	Tolerance (±%)	RDC (Ω) ±30%	Isat (mA)Typ	Irms (mA)Typ	Marking
LVS303012H-1R0□-N	1.0	1	20,30	0.056	1900	2100	1R0
LVS303012H-1R5□-N	1.5	1	20,30	0.065	1500	1850	1R5
LVS303012H-2R2□-N	2.2	1	20,30	0.080	1400	1800	2R2
LVS303012H-3R3□-N	3.3	1	20,30	0.100	1100	1600	3R3
LVS303012H-4R7□-N	4.7	1	20,30	0.130	990	1400	4R7
LVS303012H-6R8□-N	6.8	1	20,30	0.190	850	1200	6R8
LVS303012H-100□-N	10	1	20,30	0.270	720	1000	100
LVS303012H-220□-N	22	1	20,30	0.600	450	630	220

- When ordering, please specify tolerance and packaging codes.
- Tolerance : T = ±30% , M = ±20%
- L : Agilent/HP4287A+ Agilent/HP16197A, 1MHz 200mV
- RDC : Digital Milliohm Meter Chroma 16502,or equivalent
- Isat & I rms : Agilent/HP4284A, 1MHz 200mV
- Isat for Inductance drop 30% from its value without current.
- I rms for a 40°C rise above 25°C ambient.
- Operating temperature range from -25°C to 105°C. (Including self - temperature rise)

Test Instruments : HP4284A Material/Impedance Analyzer

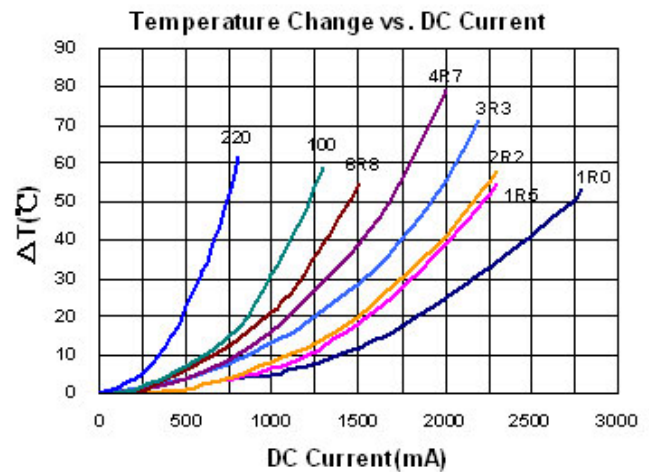
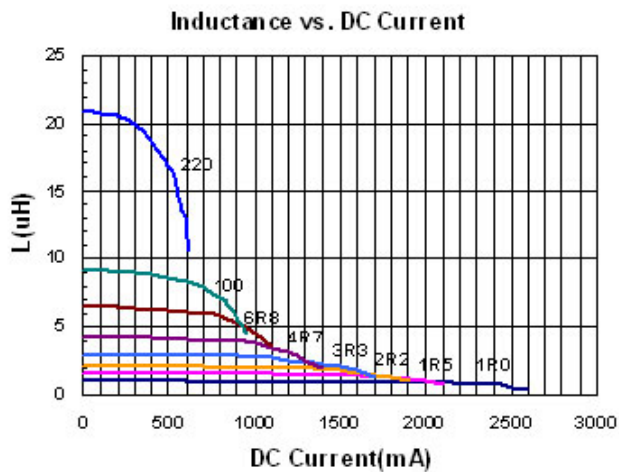

Electrical Characteristics

Part Number	Inductance (uH)	Test Frequency (MHz)	Tolerance (±%)	RDC (Ω) ±30%	Isat (mA)Typ	Irms (mA)Typ	Marking
LVS303015-1R0□-N	1.0	1	20, 30	0.056	2000	2800	1R0
LVS303015-1R5□-N	1.5	1	20, 30	0.074	1600	2400	1R5
LVS303015-2R2□-N	2.2	1	20, 30	0.079	1200	2300	2R2
LVS303015-3R3□-N	3.3	1	20, 30	0.105	1000	1900	3R3
LVS303015-4R7□-N	4.7	1	20, 30	0.130	900	1600	4R7
LVS303015-6R8□-N	6.8	1	20, 30	0.165	730	1300	6R8
LVS303015-100□-N	10	1	20, 30	0.206	600	1000	100
LVS303015-220□-N	22	1	20, 30	0.501	420	650	220

- When ordering, please specify tolerance and packaging codes.
- Tolerance : T = ±30% , M = ±20%
- L : Agilent/HP4287A+ Agilent/HP16197A, 1MHz 200mV
- RDC : Digital Milliohm Meter Chroma 16502,or equivalent
- Isat & Irms : Agilent/HP4284A, 1MHz 200mV
- Isat for Inductance drop 30% from its value without current.
- Irms for a 40°C rise above 25°C ambient.
- Operating temperature range from -25°C to 105°C. (Including self - temperature rise)

Test Instruments : HP4284A Material/Impedance Analyzer

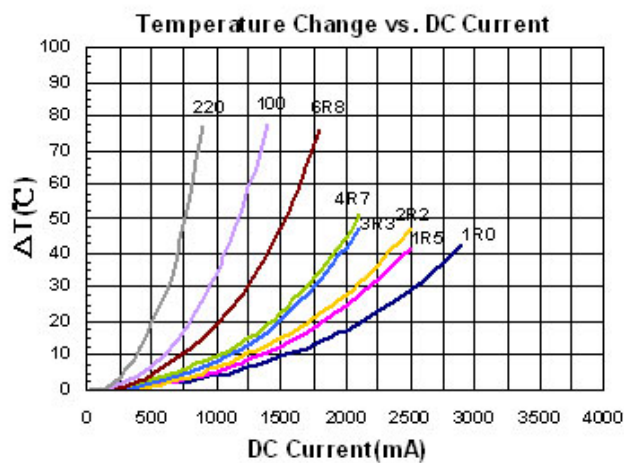
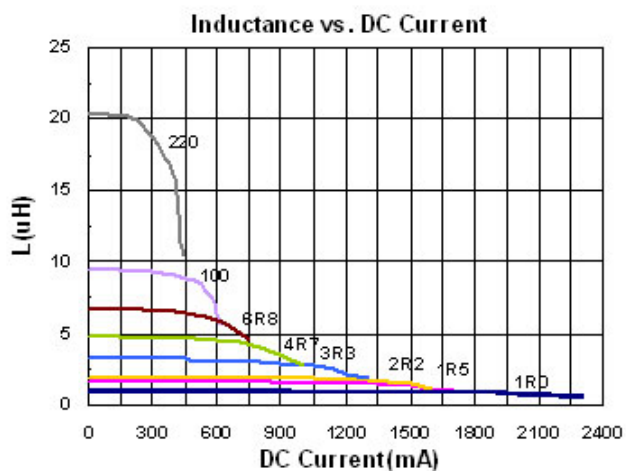

Electrical Characteristics

Part Number	Inductance (uH)	Test Frequency (MHz)	Tolerance (±%)	RDC (Ω ±30%)	Isat (mA)Typ	Irms (mA)Typ	Marking
LVS303015H-1R0□-N	1.0	1	20, 30	0.053	2000	2100	1R0
LVS303015H-1R5□-N	1.5	1	20, 30	0.070	1600	1900	1R5
LVS303015H-2R2□-N	2.2	1	20, 30	0.075	1500	1800	2R2
LVS303015H-3R3□-N	3.3	1	20, 30	0.095	1100	1600	3R3
LVS303015H-4R7□-N	4.7	1	20, 30	0.117	990	1400	4R7
LVS303015H-6R8□-N	6.8	1	20, 30	0.160	900	1200	6R8
LVS303015H-8R2□-N	8.2	1	20, 30	0.200	800	1100	8R2
LVS303015H-100□-N	10	1	20, 30	0.220	720	1000	100
LVS303015H-150□-N	15	1	20, 30	0.290	680	850	150
LVS303015H-220□-N	22	1	20, 30	0.530	480	620	220
LVS303015H-330□-N	33	1	20, 30	0.670	460	500	330
LVS303015H-470□-N	47	1	20, 30	0.960	380	400	470

- When ordering, please specify tolerance and packaging codes.
- Tolerance : T = ±30% , M = ±20%
- L : Agilent/HP4287A+ Agilent/HP16197A, 1MHz 200mV
- RDC : Digital Milliohm Meter Chroma 16502, or equivalent
- Isat & I rms : Agilent/HP4284A, 1MHz 200mV
- Isat for Inductance drop 30% from its value without current.
- I rms for a 40°C rise above 25°C ambient.
- Operating temperature range from -25°C to 105°C . (Including self - temperature rise)

Test Instruments : HP4284A Material/Impedance Analyzer

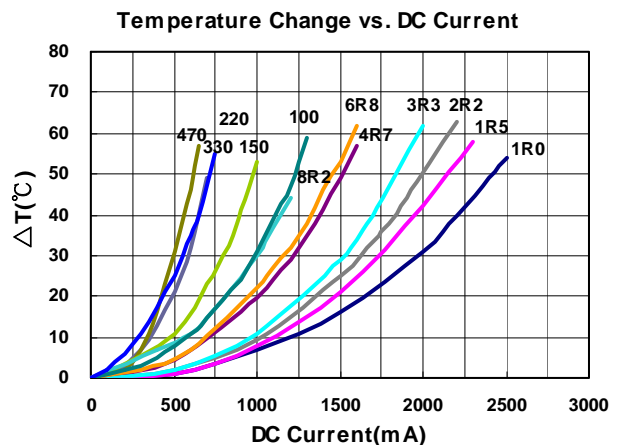
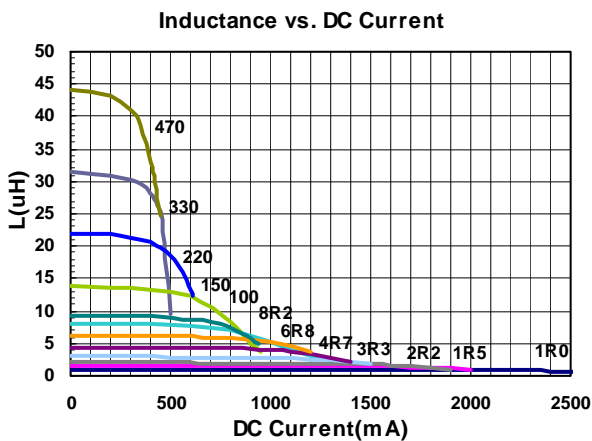

Electrical Characteristics

Part Number	Inductance (uH)	Test Frequency (KHz)	Tolerance (±%)	RDC (mΩ) ±30%	Isat (A)Typ.	Irms (A)Typ.	Marking
LVS404010-1R0□-N	1.0	100	30	60	3.6	2	1R0
LVS404010-4R7□-N	4.7	100	20, 30	220	1.4	1	4R7
LVS404010-6R8□-N	6.8	100	20, 30	360	1.1	0.7	6R8
LVS404010-100□-N	10	100	20, 30	430	1.0	0.65	100

- When ordering, please specify tolerance and packaging codes.
- Tolerance : M = ±20% , T = ±30%
- L : Agilent/HP 4284A + Agilent/HP 16334A ,100KHz with 1V.
- Isat & Irms : Agilent/HP 4284A , 100KHz with 1V.
- Rdc : Digital Milliohm Meter Chroma 16502,or equivalent
- Isat for Inductance drop 30% from its value without current.
- Irms for a 40°C rise above 25°C ambient.
- Operating temperature range from -25°C to 105°C. (Including self - temperature rise)

Test Instruments : HP4284A Material/Impedance Analyzer

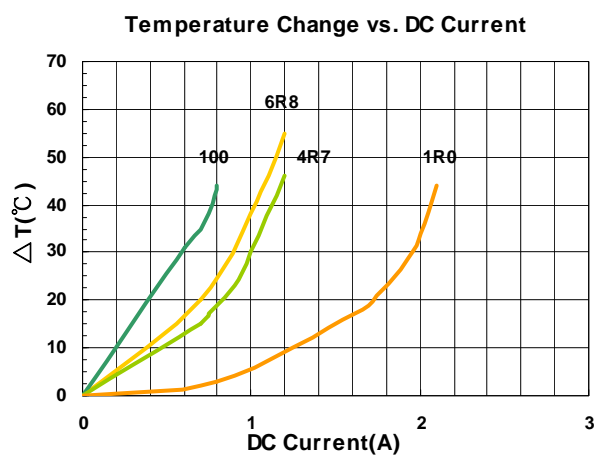
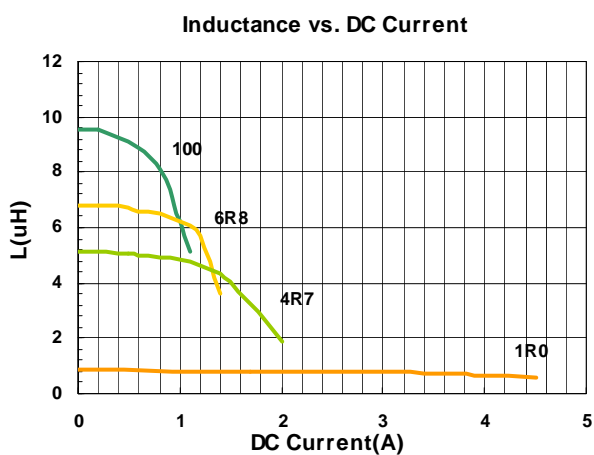

Electrical Characteristics

Part Number	Inductance (uH)	Test Frequency (KHz)	Tolerance (±%)	RDC (mΩ) ±30%	Isat (A)Typ.	Irms (A)Typ.	Marking
LVS404012-1R0□-N	1.0	100	30	48	2.50	1.70	1R0
LVS404012-1R5□-N	1.5	100	30	58	2.10	1.60	1R5
LVS404012-2R2□-N	2.2	100	20, 30	65	1.70	1.50	2R2
LVS404012-3R3□-N	3.3	100	20, 30	90	1.30	1.40	3R3
LVS404012-4R7□-N	4.7	100	20, 30	110	1.10	1.20	4R7
LVS404012-6R8□-N	6.8	100	20, 30	135	0.90	1.05	6R8
LVS404012-100□-N	10	100	20, 30	190	0.78	0.90	100
LVS404012-150□-N	15	100	20, 30	250	0.65	0.85	150
LVS404012-220□-N	22	100	20, 30	400	0.52	0.75	220
LVS404012-330□-N	33	100	20, 30	600	0.44	0.70	330
LVS404012-470□-N	47	100	20, 30	930	0.35	0.50	470

- When ordering, please specify tolerance and packaging codes.
- Tolerance : M = ±20% , T = ±30%
- L : Agilent/HP 4284A + Agilent/HP 16334A ,100KHz with 1V.
- Isat & Irms : Agilent/HP 4284A , 100KHz with 1V.
- Rdc : Digital Milliohm Meter Chroma 16502,or equivalent
- Isat for Inductance drop 30% from its value without current.
- Irms for a 40°C rise above 25°C ambient.
- Operating temperature range from -25°C to 105°C. (Including self - temperature rise)

Test Instruments : HP4284A Material/Impedance Analyzer

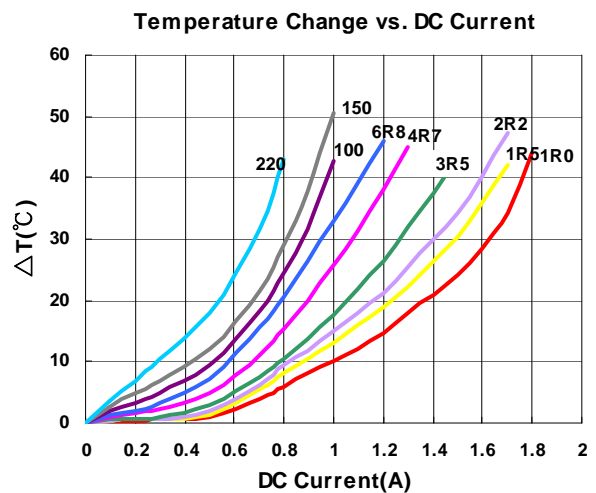
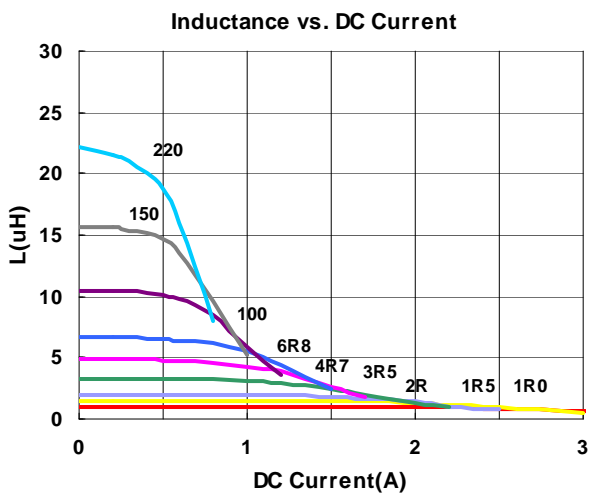

Electrical Characteristics

Part Number	Inductance (uH)	Test Frequency (KHz)	Tolerance (±%)	RDC (mΩ) ±20%	Isat (A)Typ.	Irms (A)Typ.	Marking
LVS404018-1R0□-N	1.0	100	20, 30	32	4.10	2.80	1R0
LVS404018-2R2□-N	2.2	100	20, 30	60	2.80	2.50	2R2
LVS404018-3R3□-N	3.3	100	20, 30	70	2.20	2.10	3R3
LVS404018-3R6□-N	3.6	100	20, 30	75	2.10	1.90	3R6
LVS404018-3R9□-N	3.9	100	20, 30	75	2.10	1.90	3R9
LVS404018-4R7□-N	4.7	100	20, 30	90	2.00	1.70	4R7
LVS404018-6R8□-N	6.8	100	20, 30	110	1.60	1.50	6R8
LVS404018-100□-N	10	100	20, 30	170	1.40	1.20	100
LVS404018-150□-N	15	100	20, 30	250	1.00	1.00	150
LVS404018-220□-N	22	100	20, 30	350	0.90	0.85	220
LVS404018-330□-N	33	100	20, 30	530	0.80	0.70	330
LVS404018-470□-N	47	100	20, 30	720	0.70	0.56	470
LVS404018-680□-N	68	100	20, 30	1000	0.56	0.45	680
LVS404018-101□-N	100	100	20, 30	1500	0.46	0.38	101
LVS404018-151□-N	150	100	20, 30	2500	0.35	0.30	151
LVS404018-221□-N	220	100	20, 30	4000	0.28	0.23	221

- When ordering, please specify tolerance and packaging codes.
- Tolerance : M = ±20% , T = ±30%
- L : Agilent/HP 4284A + Agilent/HP 16334A ,100KHz with 1V.
- Isat & Irms : Agilent/HP 4284A , 100KHz with 1V.
- Rdc : Digital Milliohm Meter Chroma 16502,or equivalent
- Isat for Inductance drop 30% from its value without current.
- Irms for a 40°C rise above 25°C ambient.
- Operating temperature range from -25°C to 105°C. (Including self - temperature rise)

Test Instruments : HP4284A Material/Impedance Analyzer

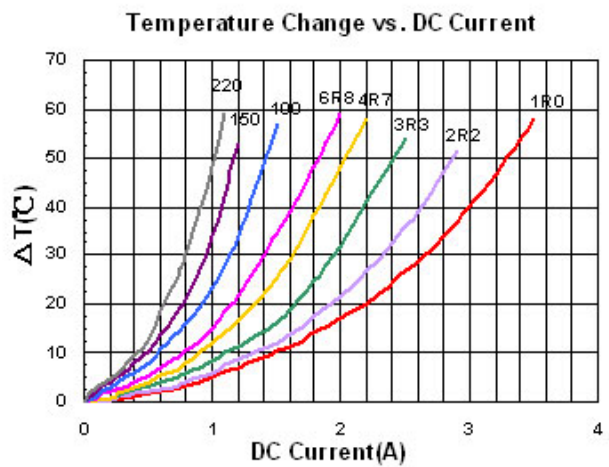
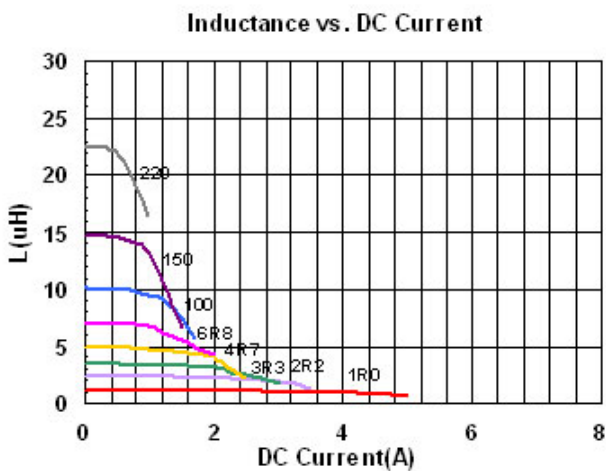

Electrical Characteristics

Part Number	Inductance (uH)	Test Frequency (KHz)	Tolerance (±%)	RDC (mΩ) ±20%	Isat (A)Typ.	Irms (A)Typ.	Marking
LVS505020-1R0□-N	1.0	100	30	21	5.1	4.0	1R0
LVS505020-1R5□-N	1.5	100	30	26	4.2	3.5	1R5
LVS505020-2R2□-N	2.2	100	30	35	3.4	3.2	2R2
LVS505020-3R3□-N	3.3	100	30	48	3.0	2.8	3R3
LVS505020-4R7□-N	4.7	100	20, 30	60	2.2	2.2	4R7
LVS505020-5R6□-N	5.6	100	20, 30	82	2.05	2.0	5R6
LVS505020-6R8□-N	6.8	100	20, 30	90	2.0	1.8	6R8
LVS505020-100□-N	10	100	20, 30	120	1.6	1.6	100
LVS505020-150□-N	15	100	20, 30	190	1.3	1.2	150
LVS505020-220□-N	22	100	20, 30	260	1.0	1.0	220
LVS505020-330□-N	33	100	20, 30	460	0.8	0.75	330
LVS505020-470□-N	47	100	20, 30	580	0.65	0.65	470

- When ordering, please specify tolerance and packaging codes.
- Tolerance : M = ±20% , T = ±30%
- L : Agilent/HP 4284A + Agilent/HP 16334A ,100KHz with 1V.
- Isat & Irms : Agilent/HP 4284A , 100KHz with 1V.
- Rdc : Digital Milliohm Meter Chroma 16502,or equivalent
- Isat for Inductance drop 30% from its value without current.
- Irms for a 40°C rise above 25°C ambient.
- Operating temperature range from -25°C to 105°C. (Including self - temperature rise)

Test Instruments : HP4284A Material/Impedance Analyzer

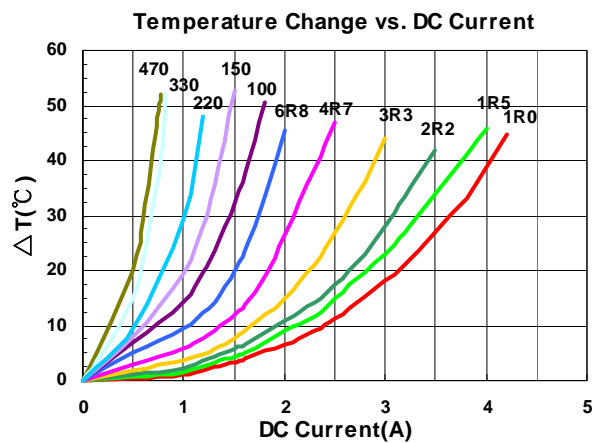
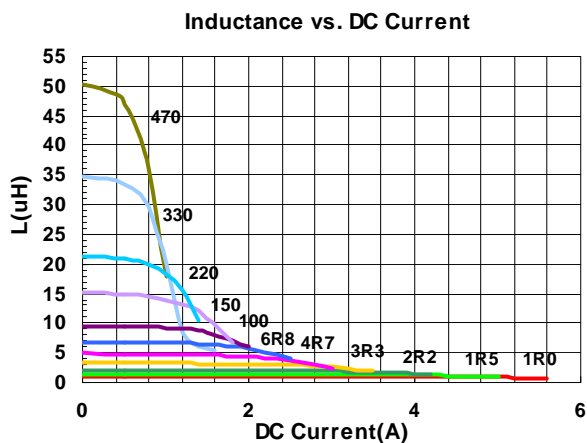

Electrical Characteristics

Part Number	Inductance (uH)	Test Frequency (KHz)	Tolerance (±%)	RDC (mΩ) ±30%	Isat (A)Typ.	Irms (A)Typ.	Marking
LVS505040-1R0□-N	1.0	100	30	14	7.5	4.6	1R0
LVS505040-1R2□-N	1.2	100	30	15	7.4	4.5	1R2
LVS505040-1R5□-N	1.5	100	30	16	7.1	4.4	1R5
LVS505040-2R2□-N	2.2	100	30	21	5.7	3.7	2R2
LVS505040-3R3□-N	3.3	100	30	26	4.8	3.5	3R3
LVS505040-4R7□-N	4.7	100	20, 30	32	4.2	3.2	4R7
LVS505040-6R8□-N	6.8	100	20, 30	50	3.3	2.4	6R8
LVS505040-100□-N	10	100	20, 30	60	2.8	2.2	100
LVS505040-150□-N	15	100	20, 30	90	2.3	1.8	150
LVS505040-220□-N	22	100	20, 30	135	1.8	1.4	220
LVS505040-270□-N	27	100	20, 30	180	1.6	1.2	270
LVS505040-330□-N	33	100	20, 30	190	1.5	1.1	330
LVS505040-470□-N	47	100	20, 30	310	1.2	0.9	470

- When ordering, please specify tolerance and packaging codes.
- Tolerance : M = ±20% , T = ±30%
- L : Agilent/HP 4284A + Agilent/HP 16334A ,100KHz with 1V.
- Isat & Irms : Agilent/HP 4284A , 100KHz with 1V.
- Rdc : Digital Milliohm Meter Chroma 16502,or equivalent
- Isat for Inductance drop 30% from its value without current.
- Irms for a 40°C rise above 25°C ambient.
- Operating temperature range from -25°C to 105°C. (Including self - temperature rise)

Test Instruments : HP4284A Material/Impedance Analyzer

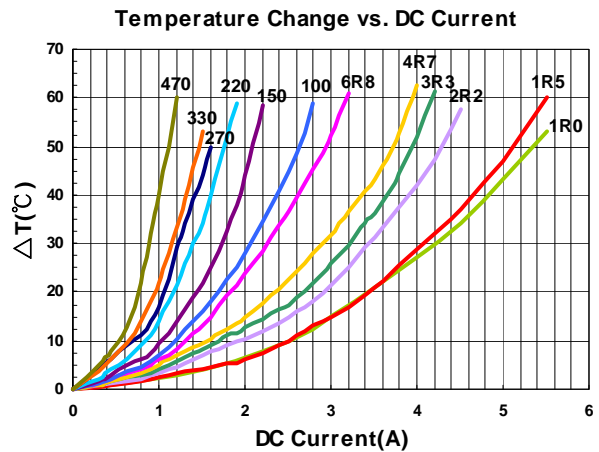
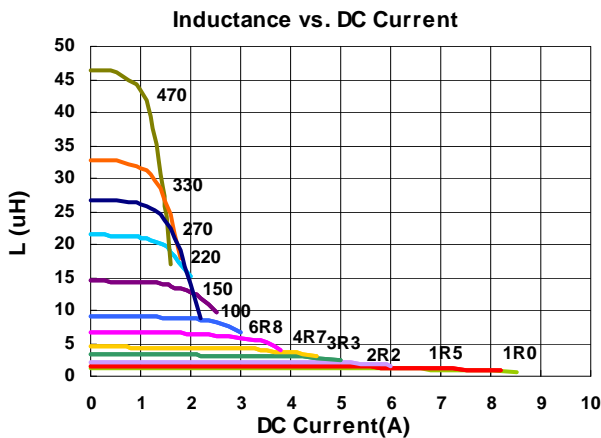

Electrical Characteristics

Part Number	Inductance (uH)	Test Frequency (KHz)	Tolerance (±%)	RDC (mΩ) ±30%	Isat (A)Typ.	Irms (A)Typ.	Marking
LVS606012-1R2□-N	1.2	100	30	65	3.50	1.60	1R2
LVS606012-2R0□-N	2.0	100	20,30	82	2.70	1.40	2R0
LVS606012-3R0□-N	3.0	100	20, 30	98	2.30	1.30	3R0
LVS606012-4R7□-N	4.7	100	20, 30	135	1.70	1.20	4R7
LVS606012-6R8□-N	6.8	100	20, 30	200	1.50	1.10	6R8
LVS606012-100□-N	10	100	20, 30	205	1.10	1.00	100
LVS606012-150□-N	15	100	20, 30	265	0.90	0.84	150
LVS606012-220□-N	22	100	20, 30	330	0.82	0.76	220
LVS606012-330□-N	33	100	20, 30	465	0.70	0.70	330
LVS606012-470□-N	47	100	20, 30	660	0.60	0.60	470
LVS606012-680□-N	68	100	20, 30	960	0.50	0.50	680
LVS606012-101□-N	100	100	20, 30	1420	0.40	0.40	101

- When ordering, please specify tolerance and packaging codes.
- Tolerance : M = ±20% , T = ±30%
- L : Agilent/HP 4284A + Agilent/HP 16334A , 100KHz with 1V.
- Isat & Irms : Agilent/HP 4284A , 100KHz with 1V.
- Rdc : Digital Milliohm Meter Chroma 16502, or equivalent
- Isat for Inductance drop 30% from its value without current.
- Irms for a 40°C rise above 25°C ambient.
- Operating temperature range from -25°C to 105°C. (Including self - temperature rise)

Test Instruments : HP4284A Material/Impedance Analyzer

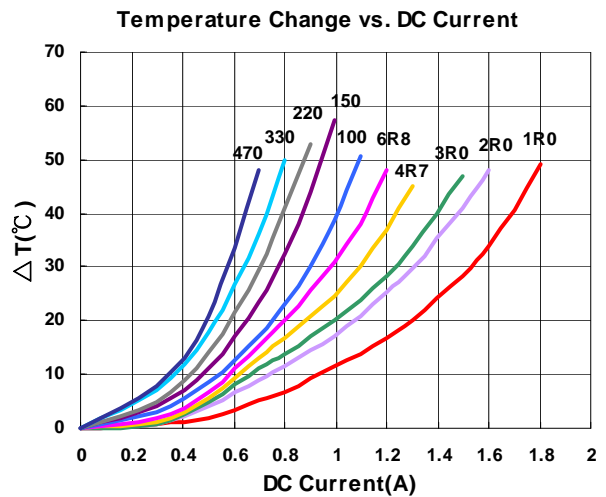
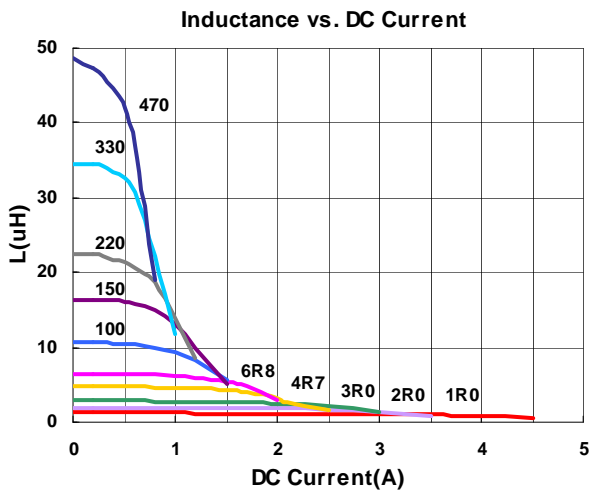

Electrical Characteristics

Part Number	Inductance (uH)	Test Frequency (KHz)	Tolerance (±%)	RDC (mΩ) ±30%	Isat (A)Typ.	Irms (A)Typ.	Marking
LVS606020-R50□-N	0.5	100	30	13	8.0	5.3	R50
LVS606020-R90□-N	0.9	100	30	18	6.3	4.2	R90
LVS606020-1R5□-N	1.5	100	30	26	5.0	3.6	1R5
LVS606020-2R2□-N	2.2	100	30	34	4.2	3.2	2R2
LVS606020-3R3□-N	3.3	100	30	40	3.2	2.7	3R3
LVS606020-4R7□-N	4.7	100	30	58	2.5	2.2	4R7
LVS606020-6R8□-N	6.8	100	20, 30	85	2.2	1.8	6R8
LVS606020-100□-N	10	100	20, 30	125	2.0	1.6	100
LVS606020-150□-N	15	100	20, 30	190	1.3	1.3	150
LVS606020-220□-N	22	100	20, 30	260	1.1	1.1	220

- When ordering, please specify tolerance and packaging codes.
- Tolerance : M = ±20% , T = ±30%
- L : Agilent/HP 4284A + Agilent/HP 16334A ,100KHz with 1V.
- Isat & Irms : Agilent/HP 4284A , 100KHz with 1V.
- Rdc : Digital Milliohm Meter Chroma 16502,or equivalent
- Isat for Inductance drop 30% from its value without current.
- Irms for a 40°C rise above 25°C ambient.
- Operating temperature range from -25°C to 105°C. (Including self - temperature rise)

Test Instruments : HP4284A Material/Impedance Analyzer

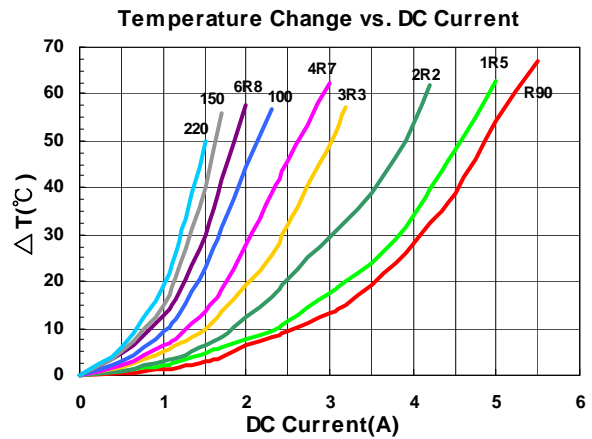
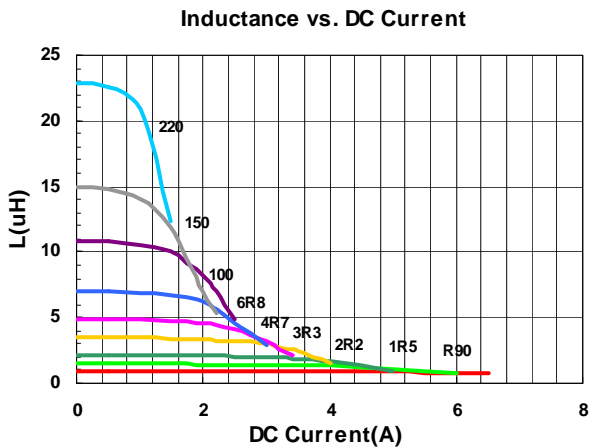

Electrical Characteristics

Part Number	Inductance (uH)	Test Frequency (KHz)	Tolerance (±%)	RDC (mΩ) ±30%	Isat (A)Typ.	Irms (A)Typ.	Marking
LVS606028-1R0□-N	1.0	100	30	13	7.6	5.2	1R0
LVS606028-1R5□-N	1.5	100	30	16	6.3	4.8	1R5
LVS606028-2R2□-N	2.2	100	30	20	5.4	4.0	2R2
LVS606028-2R7□-N	2.7	100	20, 30	26	4.9	3.7	2R7
LVS606028-3R3□-N	3.3	100	20, 30	28	4.3	3.5	3R3
LVS606028-4R7□-N	4.7	100	20, 30	38	3.7	3.2	4R7
LVS606028-6R0□-N	6.0	100	20, 30	45	3.3	2.8	6R0
LVS606028-6R8□-N	6.8	100	20, 30	50	3.1	2.7	6R8
LVS606028-100□-N	10	100	20, 30	65	2.5	2.3	100
LVS606028-150□-N	15	100	20, 30	95	2.0	1.8	150
LVS606028-220□-N	22	100	20, 30	135	1.6	1.5	220
LVS606028-330□-N	33	100	20, 30	220	1.3	1.4	330
LVS606028-470□-N	47	100	20, 30	320	1.1	1.0	470
LVS606028-680□-N	68	100	20, 30	420	0.98	0.9	680
LVS606028-101□-N	100	100	20, 30	600	0.82	0.8	101

- When ordering, please specify tolerance and packaging codes.
- Tolerance : M = ±20% , T = ±30%
- L : Agilent/HP 4284A + Agilent/HP 16334A , 100KHz with 1V.
- Isat & Irms : Agilent/HP 4284A , 100KHz with 1V.
- Rdc : Digital Milliohm Meter Chroma 16502, or equivalent
- Isat for Inductance drop 30% from its value without current.
- Irms for a 40°C rise above 25°C ambient.
- Operating temperature range from -25°C to 105°C. (Including self - temperature rise)

Test Instruments : HP4284A Material/Impedance Analyzer

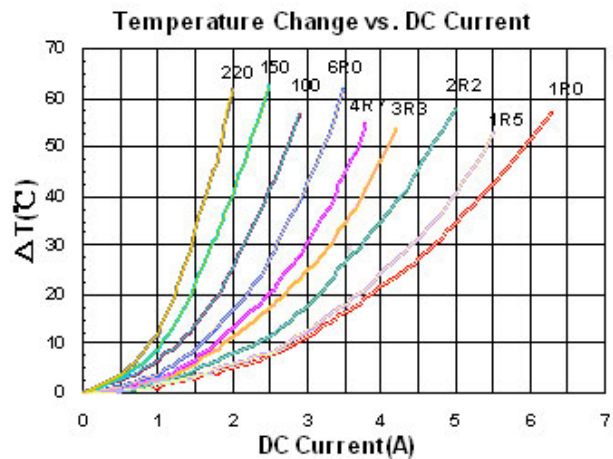
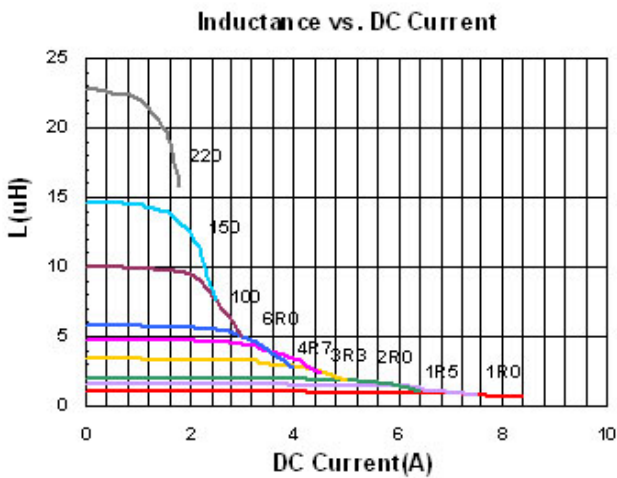

Electrical Characteristics

Part Number	Inductance (uH)	Test Frequency (KHz)	Tolerance (±%)	RDC (mΩ) ±30%	Isat (A)Typ.	Irms (A)Typ.	Marking
LVS606045-1R0□-N	1.0	100	30	12	12.2	6.5	1R0
LVS606045-1R8□-N	1.8	100	30	17	9.6	5.6	1R8
LVS606045-2R3□-N	2.3	100	30	19	8.8	5.0	2R3
LVS606045-3R0□-N	3.0	100	30	22	7.8	4.4	3R0
LVS606045-3R6□-N	3.6	100	20, 30	24	7.5	4.3	3R6
LVS606045-3R9□-N	3.9	100	20, 30	26	7.0	4.0	3R9
LVS606045-4R5□-N	4.5	100	20, 30	31	6.7	3.9	4R5
LVS606045-5R1□-N	5.1	100	20, 30	33	6.0	3.5	5R1
LVS606045-6R8□-N	6.8	100	20, 30	43	5.3	3.2	6R8
LVS606045-100□-N	10	100	20, 30	57	4.5	2.7	100
LVS606045-150□-N	15	100	20, 30	80	3.4	2.2	150
LVS606045-180□-N	18	100	20, 30	100	3.1	1.8	180
LVS606045-220□-N	22	100	20, 30	125	3.0	1.9	220
LVS606045-270□-N	27	100	20, 30	160	2.5	1.3	270
LVS606045-330□-N	33	100	20, 30	165	2.3	1.4	330
LVS606045-470□-N	47	100	20, 30	245	1.9	1.2	470
LVS606045-680□-N	68	100	20, 30	330	1.6	1.0	680
LVS606045-101□-N	100	100	20, 30	500	1.3	0.8	101
LVS606045-331□-N	330	100	20, 30	1800	0.7	0.35	331
LVS606045-102□-N	1000	100	20, 30	6000	0.4	0.22	102

- When ordering, please specify tolerance and packaging codes.
- Tolerance : M = ±20% , T = ±30%
- L : Agilent/HP 4284A + Agilent/HP 16334A ,100KHz with 1V.
- Isat & Irms : Agilent/HP 4284A , 100KHz with 1V.
- Rdc : Digital Milliohm Meter Chroma 16502,or equivalent
- Isat for Inductance drop 30% from its value without current.
- Irms for a 40°C rise above 25°C ambient.
- Operating temperature range from -25°C to 105°C. (Including self - temperature rise)

Test Instruments : HP4284A Material/Impedance Analyzer

Inductance vs. DC Current

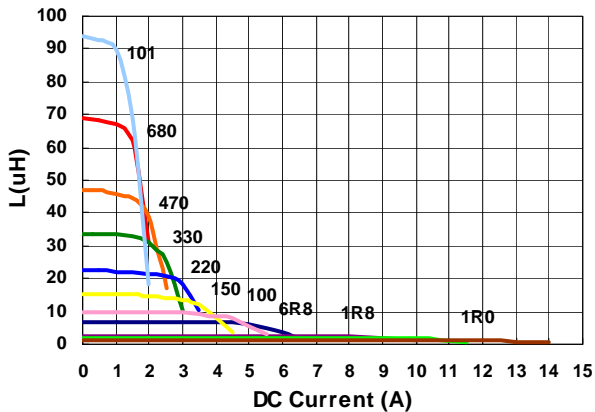

Temperature Change vs. DC Current

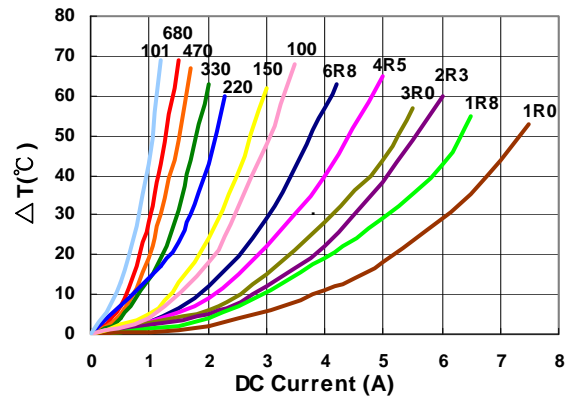

Electrical Characteristics

Part Number	Inductance (uH)	Test Frequency (KHz)	Tolerance (±%)	RDC (mΩ) Max	Isat (A)Typ.	Irms (A)Typ.	Marking
LVS606045L-2R2□-N	2.2	100	20, 30	17	6.8	5.5	2R2
LVS606045L-3R3□-N	3.3	100	20, 30	24	5.5	4.7	3R3
LVS606045L-4R7□-N	4.7	100	20, 30	30	4.6	4.0	4R7
LVS606045L-6R8□-N	6.8	100	20, 30	40	4.0	3.5	6R8
LVS606045L-100□-N	10	100	20, 30	50	3.2	3.2	100
LVS606045L-150□-N	15	100	20, 30	80	2.6	2.5	150
LVS606045L-220□-N	22	100	20, 30	120	2.1	2.0	220
LVS606045L-330□-N	33	100	20, 30	170	1.7	1.6	330

- When ordering, please specify tolerance and packaging codes.
- Tolerance : M = ±20% , T = ±30%
- L : Agilent/HP 4284A + Agilent/HP 16334A ,100KHz with 1V.
- Isat & Irms : Agilent/HP 4284A , 100KHz with 1V.
- Rdc : Digital Milliohm Meter Chroma 16502,or equivalent
- Isat for Inductance drop 30% from its value without current.
- Irms for a 40°C rise above 25°C ambient.
- Operating temperature range from -25°C to 105°C. (Including self - temperature rise)

Test Instruments : HP4284A Material/Impedance Analyzer

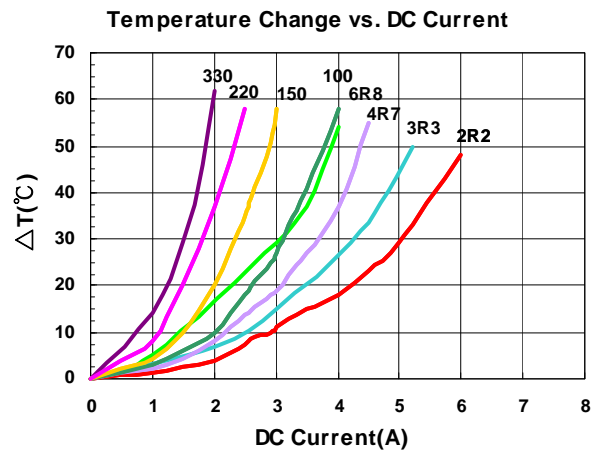
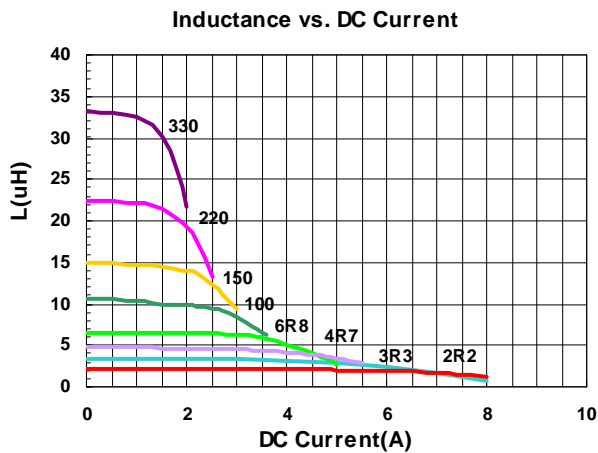

Electrical Characteristics

Part Number	Inductance (uH)	Test Frequency (KHz)	Tolerance (±%)	RDC (mΩ) ±30%	Isat (A)Typ.	Irms (A)Typ.	Marking
LVS808040-R90□-N	0.9	100	30	7	13.8	8.05	R90
LVS808040-1R4□-N	1.4	100	30	9	10.8	7.8	1R4
LVS808040-2R0□-N	2.0	100	30	11	9.6	7.4	2R0
LVS808040-2R5□-N	2.5	100	30	13	8.2	6.3	2R5
LVS808040-3R3□-N	3.3	100	30	15	7.5	6.0	3R3
LVS808040-4R7□-N	4.7	100	30	18	6	5.5	4R7
LVS808040-5R6□-N	5.6	100	20, 30	23	5.7	5.2	5R6
LVS808040-6R8□-N	6.8	100	20, 30	25	5.4	5.1	6R8
LVS808040-100□-N	10	100	20, 30	38	4.3	3.8	100
LVS808040-120□-N	12	100	20, 30	45	3.8	3.5	120
LVS808040-150□-N	15	100	20, 30	50	3.6	3.2	150
LVS808040-180□-N	18	100	20, 30	68	3.1	2.7	180
LVS808040-220□-N	22	100	20, 30	80	2.8	2.6	220
LVS808040-330□-N	33	100	20, 30	110	2.3	2.0	330
LVS808040-470□-N	47	100	20, 30	160	1.9	1.75	470
LVS808040-680□-N	68	100	20, 30	240	1.7	1.45	680
LVS808040-101□-N	100	100	20, 30	340	1.4	1.10	101
LVS808040-121□-N	120	100	20, 30	425	1.1	1.0	121
LVS808040-151□-N	150	100	20, 30	480	1.0	0.9	151
LVS808040-221□-N	220	100	20, 30	670	0.94	0.60	221
LVS808040-271□-N	270	100	20, 30	900	0.83	0.55	271
LVS808040-821□-N	820	100	20, 30	2800	0.40	0.38	821

- When ordering, please specify tolerance and packaging codes.
- Tolerance : T = ±30% , M = ±20%
- L : Agilent/HP4284A+ Agilent/HP16334A, 100KHz ,1V.
- RDC : Digital Milliohm Meter Chroma 16502,or equivalent
- Isat & Irms : Agilent/HP4284A, 100KHz ,1V.
- Isat for Inductance drop 30% from its value without current.
- Irms for a 40°C rise above 25°C ambient.
- Operating temperature range from -25°C to 105°C. (Including self - temperature rise)

Test Instruments : HP4284A Material/Impedance Analyzer

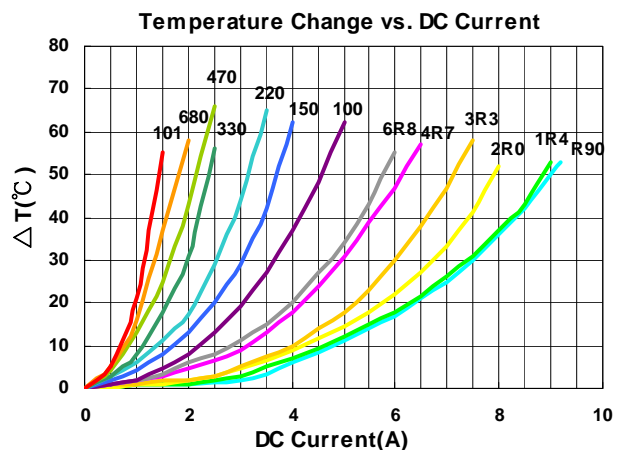
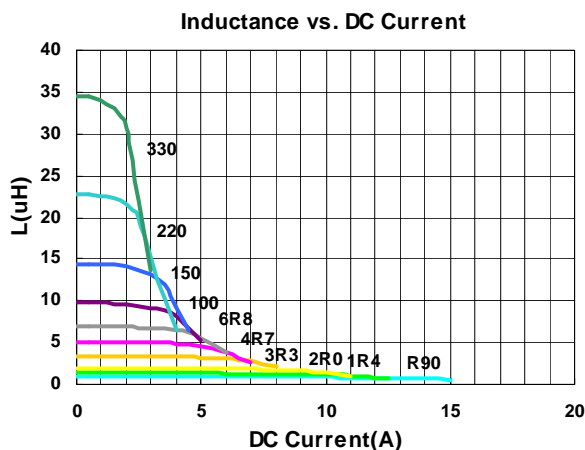

Electrical Characteristics

Part Number	Inductance (uH)	Test Frequency (KHz)	Tolerance (±%)	RDC (mΩ) Max	Isat (A)Typ.	Irms (A)Typ.	Marking
LVS808040L-1R0□-N	1.0	100	30	10	9.5	8.5	1R0
LVS808040L-2R2□-N	2.2	100	20,30	12	7.2	7.3	2R2
LVS808040L-4R7□-N	4.7	100	20,30	22	4.4	5.0	4R7
LVS808040L-8R2□-N	8.2	100	20,30	37	3.6	3.8	8R2
LVS808040L-100□-N	10	100	20,30	42	3.1	3.5	100
LVS808040L-150□-N	15	100	20,30	58	2.5	3.0	150
LVS808040L-220□-N	22	100	20,30	85	2.0	2.5	220

- When ordering, please specify tolerance and packaging codes.
- Tolerance : T = ±30% , M = ±20%
- L : Agilent/HP4284A+ Agilent/HP16334A, 100KHz ,1V.
- RDC : Digital Milliohm Meter Chroma 16502,or equivalent
- Isat & Irms : Agilent/HP4284A, 100KHz ,1V.
- Isat for Inductance drop 30% from its value without current.
- Irms for a 40°C rise above 25°C ambient.
- Operating temperature range from -25°C to 105°C . (Including self - temperature rise)

Test Instruments : HP4284A Material/Impedance Analyzer

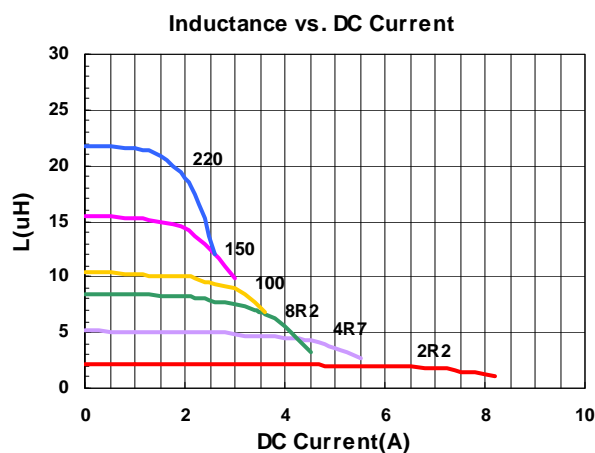
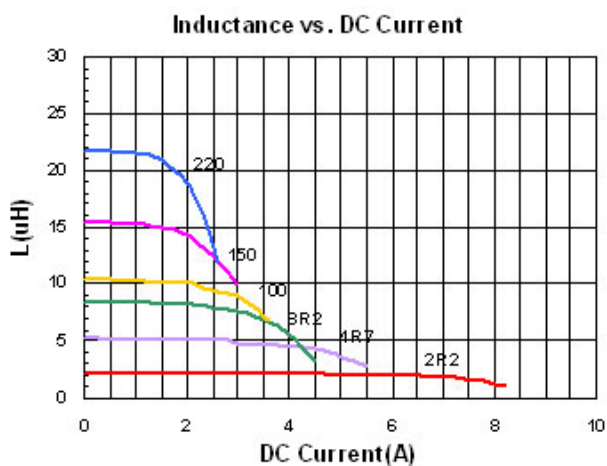

Packaging Specifications

Tape Dimensions

Figure 1

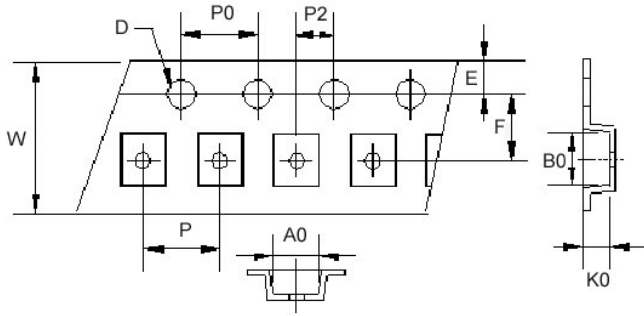

Reel Dimensions

Figure 1

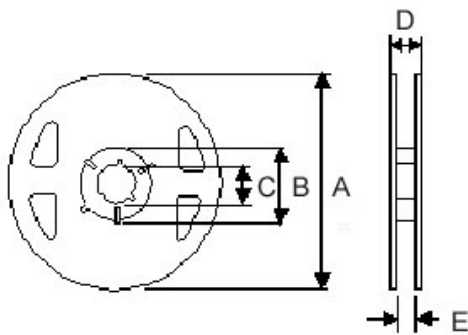

Tape Dimensions

Figure 2

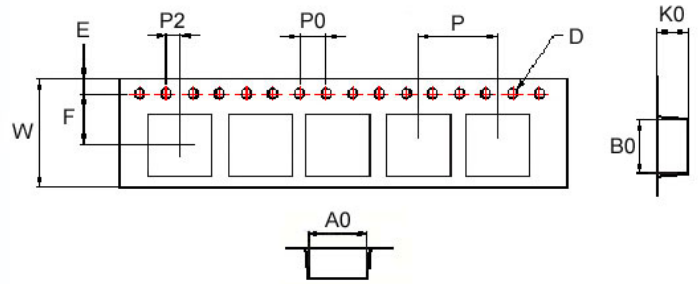

Reel Dimensions

Figure 2

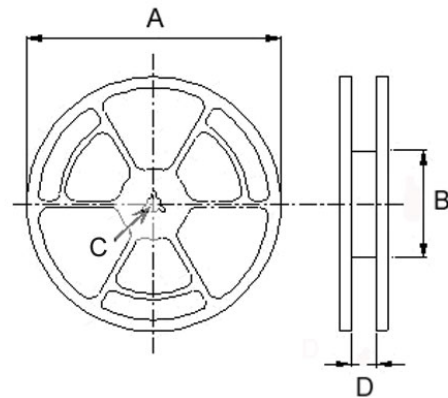

Dimensions in mm

TYPE	Fig	Tape Dimensions										Reel Dimensions					Quantity PCS / Reel
		A0	B0	K0	D	E	F	W	P	P0	P2	A	B	C	D	E	
LVS201610	1	1.80	2.20	1.15	1.55	1.75	3.5	8.1	4	4	2	180	60	13	14.4	8.4	2000
LVS252010	1	2.30	2.70	1.15	1.55	1.75	3.5	8.1	4	4	2	180	60	13	14.4	8.4	2000
LVS252012	1	2.30	2.70	1.30	1.55	1.75	3.5	8.1	4	4	2	180	60	13	14.4	8.4	2000
LVS303010	1	3.20	3.20	1.40	1.55	1.75	3.5	8.0	4	4	2	180	60	13	14.4	8.4	2000
LVS303012	1	3.20	3.20	1.40	1.55	1.75	3.5	8.0	4	4	2	180	60	13	14.4	8.4	2000
LVS303015	1	3.30	3.30	1.70	1.55	1.75	3.5	8.0	4	4	2	180	60	13	14.4	8.4	2000
LVS404012	2	4.25	4.25	1.30	1.55	1.75	5.5	12	8	4	2	178	60	13	13.2	-	1000
LVS404018	2	4.25	4.25	2.10	1.55	1.75	5.5	12	8	4	2	178	60	13	13.2	-	800
LVS505020	2	5.30	5.30	2.20	1.55	1.75	5.5	12	8	4	2	330	100	13	17.4	-	2000
LVS505040	2	5.30	5.30	4.40	1.55	1.75	5.5	12	8	4	2	330	100	13	17.4	-	1500
LVS606012	2	6.30	6.30	1.43	1.55	1.75	5.5	12	8	4	2	178	60	13	13.2	-	1000
LVS606020	2	6.20	6.20	2.00	1.55	1.75	7.5	16	12	4	2	330	100	13	17.4	-	2000
LVS606028	2	6.20	6.20	3.50	1.55	1.75	7.5	16	12	4	2	330	100	13	17.4	-	1500
LVS606045	2	6.50	6.50	4.70	1.55	1.75	7.5	16	12	4	2	330	100	13	17.4	-	1000
LVS808040	2	8.50	8.50	4.30	1.55	1.75	7.5	16	12	4	2	330	100	13	17.4	-	1000